

# PowerEdge M910



## Technical Guide



The M910 is ideal for the demanding applications at the core of most data centers, such as large databases, virtualization and messaging infrastructure.



Dell, PowerEdge, EqualLogic, PowerVault and Dell OpenManage are trademarks of Dell, Inc. Citrix is a registered trademark and XenServer is a trademark of Citrix Systems, Inc. and/or one or more of its subsidiaries, and may be registered in the United States Patent and Trademark Office and in other countries. Intel, Xeon, and SpeedStep are registered trademarks and MMX and Core are trademarks of Intel Corporation in the U.S. and other countries. Broadcom is a registered trademark and NetXtreme is a trademark of Broadcom Corporation and/or its affiliates in the United States, certain other countries and/or the EU. Brocade is a registered trademark of Brocade Communications Systems, Inc., in the United States and/or in other countries. CommVault Galaxy and Simpana are registered trademarks of CommVault Systems, Inc. Emulex is a registered trademark of Emulex Corporation. ENERGY STAR is a registered trademark of the U.S. Environmental Protection Agency. InfiniBand is a trademark of the InfiniBand Trade Association. Matrox is a registered trademark of Matrox Electronic Systems Ltd. Microsoft, Windows, Windows Server, SQL Server, and BitLocker, and Hyper-V are either registered trademarks or trademarks of Microsoft Corporation in the United States and/or other countries. Mellanox is a registered trademark of Mellanox Technologies, Inc. Novell and SUSE are registered trademarks of Novell, Inc., in the United States and other countries. Oracle and Solaris are registered trademarks of Oracle Corporation and/or its affiliates. Red Hat is a registered trademark of Red Hat, Inc. in the United States and other countries. Linux is a registered trademark of Linus Torvalds. QLogic is a registered trademark of QLogic Corporation. VMware and ESX are registered trademarks and vSphere and ESXi are trademarks of VMware, Inc. in the United States and/or other jurisdictions. vRanger, vFoglight, vConverter, Vizioncore vOptimizer, and Vizioncore vEssentials are trademarks of Vizioncore Inc. in the United States and other countries. Other trademarks and trade names may be used in this document to refer to either the entities claiming the marks and names or their products. Dell disclaims proprietary interest in the marks and names of others.

©Copyright 2011 Dell Inc. All rights reserved. Reproduction or translation of any part of this work beyond that permitted by U.S. copyright laws without the written permission of Dell Inc. is unlawful and strictly forbidden.

Revision 2

August 2011

# Table of Contents

1	Product Comparison .....	6
1.1	Overview .....	6
1.2	Powerful Performance.....	6
1.3	Scaling Capability .....	6
1.4	High Reliability .....	6
1.5	Product Comparison .....	7
2	Key Technologies.....	10
2.1	Overview .....	10
2.2	Detailed Information .....	10
2.2.1	Intel 7510 Chipset.....	10
2.2.2	Intel Xeon Processor E7 Family.....	10
2.2.3	FlexMem Bridge .....	11
2.2.4	IO Hub (IOH) with Intel QuickPath Architecture .....	11
2.2.5	DDR3 Memory .....	11
2.2.6	PCI Express Generation 2 .....	11
2.2.7	Internal Redundant SD Module .....	11
2.2.8	iDRAC6 Express .....	11
3	System Information .....	12
3.1	Overview .....	12
3.2	Product Features Summary .....	12
4	Mechanical .....	14
4.1	Overview .....	14
4.2	Module Dimensions and Weight .....	14
4.3	Front View and Features .....	15
4.4	Back View and Features.....	16
4.5	Power Supply Indicators.....	16
4.6	LED Indicators .....	16
4.7	Internal-Chassis View .....	17
4.8	Rails and Cable Management .....	17
4.9	Fans .....	17
4.10	Cabling.....	17
4.11	Control Panel/LCD .....	17
4.12	Security .....	17
4.13	Cover Latch .....	18
4.14	TPM (Trusted Platform Module) .....	18
4.15	Power Off Security.....	18
4.16	USB Key .....	18
4.17	Battery.....	18
4.18	Field Replaceable Units (FRU).....	18
4.19	User Accessible Jumpers, Sockets, and Connectors.....	18
5	Power, Thermal, and Acoustic .....	19
5.1	Power Efficiency .....	19
5.2	Thermal.....	19
5.3	Acoustics .....	20
5.4	Environmental Specifications.....	20
6	Processors .....	22
6.1	Overview .....	22
6.2	Features .....	22
6.3	Supported Processors .....	23
6.4	Processor Configurations.....	24

## Dell

6.5	FlexMem Bridge .....	24
7	Memory .....	26
7.1	Overview .....	26
7.2	DIMMs Supported .....	26
7.3	DIMM Slots .....	26
7.4	Intel 7500 Scalable Memory Buffer (SMB).....	26
7.5	Memory RAS Support.....	27
7.5.1	Sparing.....	27
7.5.2	Mirroring.....	27
7.6	Supported Memory Configurations.....	27
8	Chipset .....	28
8.1	Intel 7500 I/O Hub (IOH) .....	28
8.2	IOH QuickPath Interconnect (QPI) .....	28
8.3	PCI Express Generation 2 .....	28
8.4	Direct Media Interface (DMI) .....	28
8.5	Intel I/O Controller Hub 10 (ICH10) .....	28
8.6	PCI Express Mezzanine Connectors .....	29
9	BIOS .....	30
9.1	Overview .....	30
9.2	Supported ACPI States.....	30
10	Embedded Gigabit Ethernet Controllers on Motherboard (LOM) .....	31
11	I/O Mezzanine Card Options.....	32
11.1	Overview .....	32
11.2	Options .....	32
12	Storage .....	33
12.1	Hard Drives.....	33
12.2	Hard Disk Drive Carriers.....	33
12.3	Empty Drive Bays.....	33
12.4	Diskless Configuration Support.....	33
12.5	RAID Configurations.....	33
12.6	Storage Controllers .....	34
12.6.1	SATA Repeater.....	34
12.6.2	PERC 6/i .....	34
12.6.3	PERC H200.....	35
12.6.4	PERC H700.....	35
12.7	LED Indicators .....	35
12.8	Optical Drives.....	35
13	Video.....	36
14	Rack Information.....	37
15	Operating Systems .....	38
16	Virtualization .....	39
16.1	Overview .....	39
16.2	Advanced Infrastructure Manager by Scalent .....	39
16.3	Vizioncore .....	40
17	Systems Management.....	41
17.1	Overview .....	41
17.2	Server Management.....	41
17.3	Embedded Server Management .....	42
17.4	Lifecycle Controller and Unified Server Configurator .....	42
17.5	iDRAC6 Enterprise.....	43
17.6	Chassis Management Controller (CMC).....	44
18	Peripherals.....	45
18.1	USB peripherals.....	45

## Dell

18.2	External Storage.....	45
Appendix A.	Certifications .....	46
A 1.	Regulatory Certifications .....	46
A 2.	Product Safety Certifications.....	46
A 3.	Electromagnetic Compatibility.....	47
B 1.	Ergonomics, Acoustics and Hygienics .....	47
Appendix B.	Industry Standards .....	48

## Tables

Table 1.	Comparison of PowerEdge M910 to M710, R810, and R910.....	7
Table 2.	Product Features .....	12
Table 3.	Acoustical Performance of M1000e Chassis with Four M910 Blades Installed .....	20
Table 4.	Environmental Specifications.....	20
Table 5.	Processor Cache Sizes (Package LGA1567) .....	22
Table 6.	Supported Intel Xeon Processor E7-8800 Product Family.....	23
Table 7.	Supported Intel Xeon Processor E7-4800 Product Family.....	23
Table 8.	Supported Intel Xeon Processor E7-2800 Product Family.....	23
Table 9.	Supported Intel Xeon Processor 6500 and 7500 Series .....	23
Table 10.	Sparing and Mirroring Support.....	27
Table 11.	Supported Hard Drives.....	33
Table 12.	Factory RAID Configurations .....	34
Table 13.	Supported Storage Controllers .....	34
Table 14.	Supported Video Modes .....	36
Table 15.	Virtualization Software.....	39
Table 16.	Unified Server Configurator Features and Description.....	42
Table 17.	Features List for Base Management Functionality, iDRAC, and vFlash Media .....	43
Table 18.	Product Safety Certifications.....	46
Table 19.	Electromagnetic Compatibility Certifications.....	47
Table 20.	Ergonomics, Acoustics and Hygienics.....	47
Table 21.	Industry Standards .....	48

## Figures

Figure 1.	Front View .....	15
Figure 2.	Back View .....	16
Figure 3.	Internal Chassis View .....	17
Figure 4.	FlexMem Bridge Routing .....	25
Figure 5.	2.5" HDD Carrier .....	33

# 1 Product Comparison

## 1.1 Overview

The Dell™ PowerEdge™ M-Series blade servers are designed to help cut operating expenses through energy efficiency, scalability, product flexibility, and efficient use of data center space.

The PowerEdge M910 provides significant performance and reliability in a scalable, full-height, four-socket blade server, allowing the deployment of large Enterprise-class applications as well as the ability to support heavy virtualization or workload consolidation in maximum density.

When combined with Dell's world-class storage, management, and support offerings, the result is a total enterprise solution that can help you optimize your IT environment and expenses.

## 1.2 Powerful Performance

The PowerEdge M910 was designed to meet the needs of nearly any IT infrastructure or environment. Built with the powerful Intel® Xeon® processor E7 family or Intel Xeon processor 7500 and 6500 series, and including advanced systems management capabilities, the M910 is ideal for the demanding applications at the core of most data centers, such as large databases, virtualization and messaging infrastructure.

Memory is a critical component for performance, especially for heavy virtualization and high-end database needs. With this in mind, the PowerEdge M910 was designed with 32 DIMM slots allowing up to 512 GB of ECC DDR3 RAM to be supported, allowing these memory-intensive applications to have ample resources at their disposal.

## 1.3 Scaling Capability

Many servers may be able to take advantage of the large memory support that modern architectures provide, but only Dell offers FlexMem Bridge technology, which allows the M910 to seamlessly scale from 16 GB to 512 GB of DDR3 RAM in either two-socket or four-socket configurations. This patent-pending technology allows Dell to deliver a unique platform that can seamlessly scale as customer and application needs dictate, without having to “rip and replace” existing server infrastructure.

In addition to allowing significant memory and processor scaling capabilities, the compact form-factor of Dell blades allows the ability to scale down the amount of space that your core application servers require. By utilizing the PowerEdge M910, you can deploy up to eight next generation 4-socket servers in only 10U of rack space, which is less than one-third of the space required using traditional 4U four-socket rack servers.

## 1.4 High Reliability

With the PowerEdge M910, Dell continues its unrelenting focus on reliability. The PowerEdge M910 utilizes the redundant power, cooling, and networking infrastructure provided by the Dell M1000e Blade enclosure. The PowerEdge M910 itself incorporates improvements and features for maximum protection against potential downtime, such as the ability to support three fully redundant fabrics per blade and the inclusion of a dual-media redundant embedded hypervisor.

The PowerEdge M910 also utilizes the Intel Xeon processor E7 family or Intel Xeon processor 7500 and 6500 series, which are designed to automatically monitor, report, and recover from hardware errors in order to maintain data integrity and keep mission-critical services online.

As with all Dell PowerEdge servers, the M910 is manufactured with our “one-touch” factory build process. This process is designed to ensure just one person is responsible for the entire server build,

Dell

resulting in greater quality control. In addition, every fully configured Dell server is tested (and re-tested) before it leaves the factory to ensure maximum reliability.

Product documentation is available at [Support.Dell.com/Manuals](http://Support.Dell.com/Manuals). Information for the chassis can be found in the [PowerEdge M1000e Technical Guide](#).

## 1.5 Product Comparison

Table 1. Comparison of PowerEdge M910 to M710, R810, and R910

Feature	M910	M710	R810	R910
<b>Processor</b>	2 socket or 4 socket Intel® Xeon® E7-2800, E7-4800 and E7-8800 product family or Intel Xeon processor 6500 and 7500 series	2 socket Intel® Xeon® processors 5500 and 5600 series	2 socket or 4 socket Intel® Xeon® E7-2800, E7-4800, and E7-8800 product family Intel Xeon processor 6500 and 7500 series	4 socket Intel® Xeon® E7-4800 and E7-8800 product family Intel Xeon processor 7500 series
<b>Front Side Bus</b>	Intel QuickPath Interconnect (QPI)	Intel QuickPath Interconnect (QPI)	Intel QuickPath Interconnect (QPI)	Intel QuickPath Interconnect (QPI)
<b>L3 Cache</b>	30MB	8MB	30MB	30MB
<b>Chipset</b>	Intel® 7510	Intel® 5520	Intel® 7510	Intel® 7510
<b>DIMMs</b>	32 x DDR3	18 x DDR3	32 x DDR3	64 x DDR3
<b>Form Factor</b>	Full-height blade, dual slot	Full-height blade, dual slot	2U rack	4U rack
<b>Hard Drive Bays</b>	2 x 2.5" hot-plug	4 x 2.5" hot-plug	6 x 2.5" hot-plug	16 x 2.5" hot-plug
<b>Hard Drive Types</b>	2.5" SAS SSD, SATA SSD, SAS (15K, 10K), nearline SAS (7.2K)	2.5" SAS SSD, SATA SSD, SAS (15K, 10K), nearline SAS (7.2K)	2.5" SATA SSD, SAS (10K, 15K), nearline SAS (7.2K), SATA (7.2K)	2.5" SATA SSD, SAS (15K, 10K), nearline SAS (7.2K), SATA (7.2K)
<b>Availability</b>	Hot-plug hard drives Hot-plug redundant power and cooling ECC memory Single Device Data Correction (SDDC) Support for memory demand and patrol scrubbing High availability failover cluster support	Hot-plug hard drives Hot-plug redundant power and cooling ECC memory Single Device Data Correction (SDDC) Support for memory demand and patrol scrubbing High availability failover cluster support	Hot-plug hard drives Hot-plug redundant power and cooling ECC memory Single Device Data Correction (SDDC) Support for memory demand and patrol scrubbing High availability failover cluster support	Hot-plug hard drives Hot-plug redundant power and cooling ECC memory Single Device Data Correction (SDDC) Support for memory demand and patrol scrubbing High availability failover cluster support

Feature	M910	M710	R810	R910
<b>Integrated Standard Hard Drive Controller</b>	PERC H200/H700 (factory installed) and PERC6 as custom kit	PERC H200/H700	PERC H200/H700 PERC6/i	PERC H200/H700
<b>Optional Hard Drive Controller</b>	H200/H700 Integrated controller (battery backup for the H700 and PERC6/i options only)	SAS6/iR PERC6/i with RAID battery	PERC H800 or 6Gbps SAS	PERC H800 or 6Gbps SAS
<b>Server Management</b>	iDRAC6 Enterprise, BMC, IPMI 2.0, Dell OpenManage™, Unified Server Configurator, Lifecycle Controller, Chassis Management Controller Chassis Management Controller (CMC) on M1000e <b>Optional:</b> vFlash media	iDRAC6 Enterprise, BMC, IPMI 2.0, Dell OpenManage™, Unified Server Configurator, Lifecycle Controller, Chassis Management Controller Chassis Management Controller (CMC) on M1000e <b>Optional:</b> vFlash media	iDRAC6 Express, BMC, IPMI 2.0, Dell OpenManage™, Unified Server Configurator, Lifecycle Controller <b>Optional:</b> iDRAC6 Enterprise, vFlash media	iDRAC6 Express, BMC, IPMI 2.0, Dell OpenManage™, Unified Server Configurator, Lifecycle Controller <b>Optional:</b> iDRAC6 Enterprise, vFlash media
<b>Slots</b>	Four x8 PCIe mezzanine cards	Four x8 PCIe mezzanine cards	6 PCIe Gen2 slots + 1 storage slot: Five x8 slots One x4 slot One storage x4 slot	<b>Standard:</b> 7 PCIe Gen2 slots (2 x4, 4 x8, 1 x16) <b>Optional:</b> 10 PCIe Gen2 (6 x4, 4 x8) Slot5 is G1
<b>NIC/LOM</b>	4-port (4 x 1GbE) Embedded NIC Broadcom® BCM5709S	4-port (4 x 1GbE) Embedded NIC Broadcom® BCM5709S	4-port (4 x 1GbE) Embedded NIC Broadcom® BCM5709C <b>Optional:</b> Various NICs available	4-port (4 x 1GbE) Embedded NIC Broadcom® BCM5709C, or 4-port (2 x 10Gb SFP+ and 2 x 1GbE) Embedded NIC Broadcom 57711 + Broadcom BCM5709C <b>Optional:</b> Various NICs available
<b>USB</b>	3 front, 1 internal	3 front, 1 internal	2 front, 4 back, 1 internal	2 front, 2 back, 1 internal



## Dell

Feature	M910	M710	R810	R910
Power Supplies	See the <a href="#">PowerEdge M1000e Technical Guide</a>	See the <a href="#">PowerEdge M1000e Technical Guide</a>	Hot-plug, redundant	4 x 750W (Energy Smart) or 4 x 1100W (high-output)

## 2 Key Technologies

### 2.1 Overview

The Dell™ PowerEdge™ M910 implements a number of new technologies:

- Intel® Xeon® E7-2800, E7-4800, and E7-8800 product family
- Intel 7510 Chipset

The PowerEdge M910 also implements the following key technologies:

- FlexMem Bridge
- IO Hub (IOH) with Intel QuickPath Architecture
- DDR3 memory
- PCI Express® Generation 2
- Optional Redundant SD media for embedded hypervisor
- Integrated Dell Remote Access Controller 6 (iDRAC6) Express

### 2.2 Detailed Information

#### 2.2.1 Intel 7510 Chipset

The 7510 chipset is designed to support Intel Xeon processor E7-2800, E7-4800, and E7-8800 product families, Intel Xeon processor 6500 and 7500 series 4S family, Intel QuickPath Interconnect (QPI), DDR3 memory technology, and PCI Express Generation 2 (PCIe Gen2).

#### 2.2.2 Intel Xeon Processor E7 Family

Key features of the Intel Xeon processor E7-2800, E7-4800, and E7-8800 product families include:

- Up to ten cores per processor
- Up to 30 MB shared L3 cache
- 32 nm process technology
- Intel Trusted Execution Technology (TXT) and AESNI (AES New Instructions)
- RAS DDDC (Double Device Data Correct)
- Intel HyperThreading (2 threads/core)

Key features of the Intel Xeon processor 6500 and 7500 series include:

- Up to eight cores per processor
- Four full-width, bidirectional point-to-point Intel QuickPath Interconnect (QPI) links at 6.4 GT/s
- Four Intel Scalable Memory Interconnects (SMI) at 6.4 GT/s
- Socket: LS, LGA 1567 package
- No termination required for non-populated processors (must populate processor socket 1 first)
- 64-byte cache line size
- RISC/CISC hybrid architecture
- Compatible with existing x86 code base
- Optimized for 32-bit code
- Intel MMX™ support
- Execute Disable Bit
- Intel Wide Dynamic Execution (Executes up to four instructions per clock cycle)
- Simultaneous Multi-Threading (SMT) capability (2 threads/core)

Dell

- Support for CPU Turbo Mode on certain SKUs (Increases processor frequency if operating below thermal, power, and current limits)
- Streaming SIMD (Single Instruction, Multiple Data) Extension 4
- Intel 64 Technology
- Intel VT-x and VT-d Technology for virtualization support
- Enhanced Intel SpeedStep® Technology
- Demand-based switching for active processor power management as well as support for ACPI P-States, C-States, and T-States

### 2.2.3 FlexMem Bridge

The PowerEdge M910 also introduces a new, Dell patent-pending technology which will allow flexibility in processor and memory scalability—FlexMem Bridge. The FlexMem Bridge allows the full amount of addressable DIMMs on 4-Socket systems with Intel Xeon E7-2800, E7-4800 and E7-8800 product family and Intel Xeon processor 7500 and 6500 series to be accessed, even when only 2 of the processors are in place, in a completely passive solution (no active components).

### 2.2.4 IO Hub (IOH) with Intel QuickPath Architecture

The Intel QuickPath Architecture consists of serial point-to-point interconnects for the processors and the system IOH. The M910 has a total of eight QuickPath Interconnects (QPI) lines: six links connecting the processors and two links connection processors 1 and 2 with the IOH.

### 2.2.5 DDR3 Memory

The M910 uses DDR3 memory which provides a high-performance, high-speed memory interface capable of low latency response and high throughput. The M910 supports Registered ECC DDR3 DIMMs (RDIMMs).

The DDR3 memory interface consists of eight Intel Scalable Memory Buffers (SMBs), each of which has two DDR3 memory channels. Each channel supports up to two RDIMMs for single/dual/quad rack. By limiting to two DIMMs per DDR channel, the system can support quad-rank DIMMs at 1067MHz.

### 2.2.6 PCI Express Generation 2

PCI Express is a serial point-to-point interconnect for I/O devices. PCIe Gen2 doubles the signaling bit rate of each lane from 2.5 Gb/s to 5 Gb/s. Each of the PCIe Gen2 ports is backwards-compatible with Gen1 transfer rates.

### 2.2.7 Internal Redundant SD Module

The Internal SD Module is dedicated for an SD Flash Card with embedded Hypervisor for virtualization. The SD Flash Card contains a bootable OS image for virtualized platforms. The persistent storage solution on the M910 allows for redundant SD cards.

### 2.2.8 iDRAC6 Express

The iDRAC6 Express feature set is a managed persistent storage space for server provisioning data. It consists of 1 GB flash and vFlash media (an optional externally accessible SD card). vFlash media offers the hot-plug portability and increased storage capacity benefits of SD while still being managed by the system.

## 3 System Information

### 3.1 Overview

The Dell™ PowerEdge™ M910 is an innovative blade design that allows scaling from two to four sockets (no single- or 3-socket support) based on a new generation of Intel four-socket enhanced processors, RAM, and management while still taking advantage of the M1000e chassis architecture. Along with the M1000e chassis, the PowerEdge M910 server leads the industry in high speed, redundant IO throughput and power efficiency with more RAM slots in the 2-socket space.

### 3.2 Product Features Summary

Table 2 lists a summary of features for the PowerEdge M910. For the latest information on supported features, visit [Dell.com](http://Dell.com).

Table 2. Product Features

Feature	Dell PowerEdge M910
Processors	Eight-core Intel® Xeon® processor 7500 and 6500 series Ten-core Intel Xeon E7-2800, E7-4800 and E7-8800 product family
Chipset	Intel E7510
Memory <sup>1</sup>	Up to 512GB (32 DIMM slots): 2GB/4GB/8GB/16GB ECC DDR3 up to 1066MHz
Drive Bays	Two 2.5" SAS or SSD hot-swappable drives
Storage <sup>1</sup>	<b>Hot-plug hard drive options:</b> 2.5" SAS SSD, SATA SSD, SAS (15K, 10K), nearline SAS (7.2K) <b>Maximum internal storage:</b> Up to 2TB per blade <b>External storage:</b> For information about Dell external storage options, visit <a href="http://Dell.com/Storage">Dell.com/Storage</a> .
RAID Controller Options	PERC H200 Modular (6Gb/s) PERC H700 Modular (6Gb/s) with 512MB battery-backed cache; 512MB, 1GB Non-Volatile battery-backed cache
I/O Mezzanine Card Options	Fully populated mezzanine card slots and switch modules will yield three highly available, redundant I/O fabrics per blade. 1Gb and 10Gb Ethernet: Broadcom® Dual-Port Gb Ethernet with TOE (BCM-5709S) Intel Quad-Port Gb Ethernet Broadcom Quad-Port Gb Ethernet (BCM-5709S) Intel Dual-Port 10Gb Ethernet Broadcom Dual-Port 10Gb Ethernet (BCM-57711) 10Gb Enhanced Ethernet & Converged Network Adapters (CEE/DCB): Intel Dual-Port 10Gb Enhanced Ethernet (FCoE Ready for Future Enablement) Emulex® Dual-Port Converged Network Adapter (OCM10102-F-M)—Supports CEE/DCB 10GbE + FCoE QLogic® Dual-Port Converged Network Adapter (QME8142)—Supports CEE/DCB 10GbE + FCoE Dual-Port QLogic Converged Network Adapter (QME8242-k) - Supports 10GbE + NPAR

Feature	Dell PowerEdge M910
	Brocade® BR1741M-k Dual-Port Mezzanine CNA Fibre Channel: QLogic Dual-Port FC8 Fibre Channel Host Bus Adapter (HBA) (QME2572) Emulex Dual-Port FC8 Fibre Channel Host Bus Adapter (HBA) (LPe1205-M) Emulex 8 or 4 Gb/s Fibre Channel Pass-Through Module InfiniBand™: Mellanox® Dual-Port ConnectX™ Quad Data Rate (QDR) InfiniBand
<b>Operating Systems</b>	Microsoft® Windows Server® 2008 SP2, x86/x64 (x64 includes Hyper-V™) Microsoft Windows Server 2008 R2 SP1, x64 (includes Hyper-V v2) Microsoft Windows HPC Server 2008 Novell® SUSE® Linux® Enterprise Server Red Hat® Enterprise Linux Oracle® Solaris™ Virtualization Options: Citrix® XenServer™ Microsoft Hyper-V through Microsoft Windows Server 2008 VMware® vSphere™ 4.1 (including VMware ESX® 4.1 or VMware ESXi™ 4.1) For more information on the specific versions and additions, visit <a href="http://Dell.com/OSsupport">Dell.com/OSsupport</a> .
<b>Featured Database Applications</b>	Microsoft SQL Server® solutions (see <a href="http://Dell.com/SQL">Dell.com/SQL</a> ) Oracle database solutions (see <a href="http://Dell.com/Oracle">Dell.com/Oracle</a> )
<b>Power Supply</b>	Supplied by Dell PowerEdge M1000e Blade Chassis
<b>Video</b>	Matrox® G200eW with 8MB memory
<b>Systems Management</b>	Dell OpenManage™ BMC, IPMI 2.0 compliant Unified Server Configurator Lifecycle Controller iDRAC6 Enterprise with optional vFlash media Remote Management: iDRAC6 Enterprise with optional vFlash media Microsoft System Center Essential (SCE) 2010 v2
<b>Embedded Hypervisor</b>	Optional dual-media redundant hypervisor
<sup>1</sup> GB means 1 billion bytes and TB equals 1 trillion bytes; actual capacity varies with preloaded material and operating environment and will be less.	

## 4 Mechanical

### 4.1 Overview

The Dell™ PowerEdge™ M910 is a full-height blade server that requires an M1000e chassis to operate. The M910 occupies two slots in the M1000e rack chassis for a maximum of eight blade servers in one M1000e chassis. The M910 can be mixed with other existing Dell blades and is designed to mix with possible future half-height-double-wide and full-height-double-wide blades. Some highlights include:

- Support for RAID
- Support for persistent storage (internal USB connector and two external SD card slots)

Refer to the [PowerEdge M1000e Technical Guide](#) for information on fans, power and power supply, racks, security, and other chassis information.

### 4.2 Module Dimensions and Weight

Height: 38.5cm (15.2in)

Width: 5cm (2in)

Depth: 48.6cm (19.2in)

Weight: 13.1kg (29lb) maximum configuration

Dell

## 4.3 Front View and Features

Figure 1 shows the front view of the M910.



Figure 1. Front View

See the Blade Features section in the About Your System chapter of the *Dell PowerEdge Modular Systems Hardware Owner's Manual* on [Support.Dell.com/Manuals](http://Support.Dell.com/Manuals) for more information.

## 4.4 Back View and Features

Figure 2 shows the back view of the M910.



Figure 2. Back View

See the Blade Features section in the About Your System chapter of the *Dell PowerEdge Modular Systems Hardware Owner's Manual* on [Support.Dell.com/Manuals](http://Support.Dell.com/Manuals) for more information.

## 4.5 Power Supply Indicators

The power supplies must be connected to a power distribution unit (PDU), and not directly to an electrical outlet. The power supplies require a 200V-240V power source.

See the Power Supply Indicators section in the About Your System chapter of the *Dell PowerEdge Modular Systems Hardware Owner's Manual* on [Support.Dell.com/Manuals](http://Support.Dell.com/Manuals) for more information.

## 4.6 LED Indicators

Each disk drive carrier has two LED indicators visible from the front of the system. One is a green LED for disk activity and the other is a bicolor (green/amber) LED for status information. The activity LED is driven by the disk drive during normal operation. The bicolor LED is controlled by the SEP device on the backplane. Both LEDs are used to indicate certain conditions under direction of a storage controller.



## 4.7 Internal-Chassis View

Figure 3 shows the internal-chassis view of the M910.

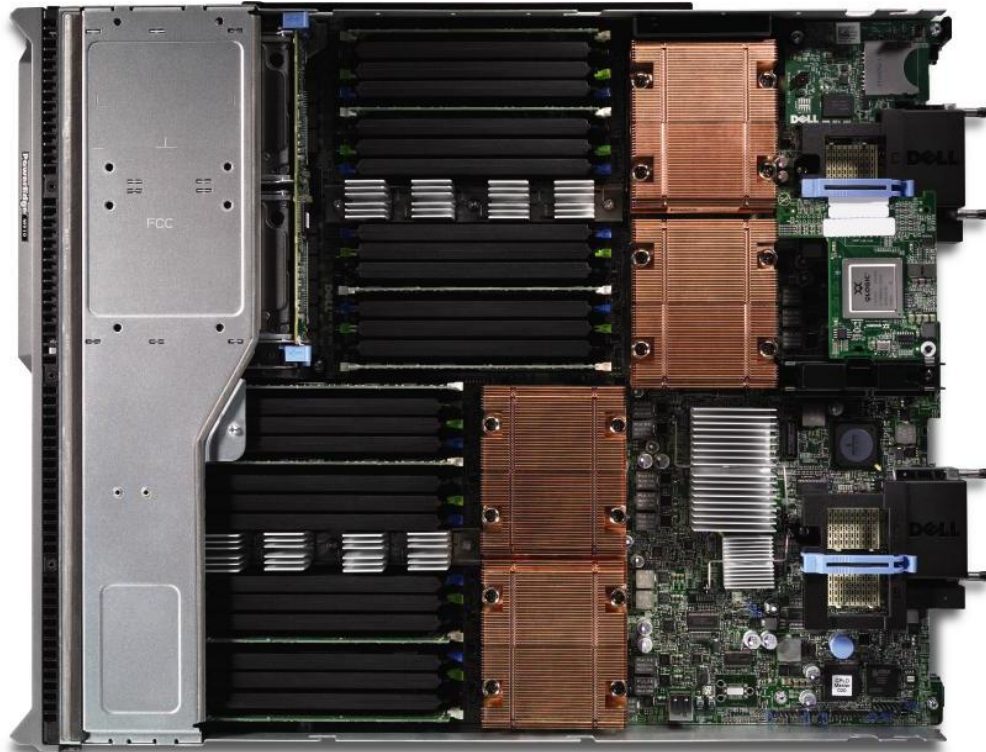

Figure 3. Internal Chassis View

## 4.8 Rails and Cable Management

See the [PowerEdge M1000e Technical Guide](#).

## 4.9 Fans

For detailed information, see the *Dell PowerEdge Modular Systems Hardware Owner's Manual* on [Support.Dell.com/Manuals](#).

## 4.10 Cabling

For detailed information, see the *Dell PowerEdge Modular Systems Hardware Owner's Manual* or the *Rack Installation Guide* on [Support.Dell.com/Manuals](#).

## 4.11 Control Panel/LCD

For detailed information, see the *Dell PowerEdge Modular Systems Hardware Owner's Manual* on [Support.Dell.com/Manuals](#).

## 4.12 Security

The M910 offers a configurable client IP address range for clients connecting to iDRAC6. For additional information regarding the PowerEdge M910 security features, see the *Dell PowerEdge Modular Systems Hardware Owner's Manual* on [Support.Dell.com/Manuals](#).

## 4.13 Cover Latch

The blade module includes a latch for the cover. See the Opening and Closing the Blade section of the Installing Blade Components chapter in the *Dell PowerEdge Modular Systems Hardware Owner's Manual* on [Support.Dell.com/Manuals](http://Support.Dell.com/Manuals) for more information.

## 4.14 TPM (Trusted Platform Module)

The TPM is used to generate/store keys, protect/authenticate passwords, and create/store digital certificates. TPM can also be used to enable the BitLocker™ hard drive encryption feature in Microsoft® Windows Server® 2008. TPM is enabled through a BIOS option and uses HMAC-SHA1-160 for binding. TCM is available in China.

## 4.15 Power Off Security

Through the CMC, the front USB's and power button can be disabled so as to not allow any control of the system from the front of the blade.

## 4.16 USB Key

The M910 supports the following USB devices:

- DVD (bootable; requires two USB ports)
- USB Key (bootable)
- Keyboard (only one USB keyboard is supported)
- Mouse (only one USB mouse is supported)

## 4.17 Battery

A replaceable coin cell CR2032 3V battery is mounted on the planar to provide backup power for the Real-Time Clock and CMOS RAM on the ICH9 chip.

## 4.18 Field Replaceable Units (FRU)

The planar contains a serial EEPROM to contain FRU information including Dell part number, part revision level, and serial number.

## 4.19 User Accessible Jumpers, Sockets, and Connectors

For information, see the System Board Information chapter in the *Dell PowerEdge Modular Systems Hardware Owner's Manual* on [Support.Dell.com/Manuals](http://Support.Dell.com/Manuals).

## 5 Power, Thermal, and Acoustic

### 5.1 Power Efficiency

One of the main features of blade servers is enhanced power efficiency. The Dell™ PowerEdge™ M910 achieves higher power efficiency by implementing the following features:

- User-configurable power options with the M1000e Chassis Management Controller (CMC)
- Improved power budgeting
- Voltage regulator efficiency improvements
- Processor VR dynamic phase shedding
- Switching regulators instead of linear regulators
- Closed-loop thermal throttling
- Use of DDR3 memory (lower voltage compared to DDR2)
- Memory VR static phase shedding
- BIOS Power/Performance options page
- Active Power Controller (BIOS-based CPU P-state manager)
- Ability to throttle memory
- Ability to disable a processor core
- Ability to turn off embedded NICs or PCIe lanes when not being used
- Energy Smart components at the M1000e chassis level to selectively enable more computing performance with less power consumption

### 5.2 Thermal

The PowerEdge M910 delivers uncompromising computing performance with a robust thermal design that efficiently manages the server component temperatures. The M910 thermal management algorithms use as many as 46 thermal sensors to meet the required cooling level while minimizing fan speeds. The thermal management algorithms also take inventory of the system hardware configuration while simultaneously monitoring the component temperature sensors throughout the system to intelligently control system fans and throttle components when needed to maintain desired power consumption and reliability levels. Closed-loop thermal monitoring of all 32 DIMMs aids in minimizing chassis fan power. The M910 is designed to maintain full performance across the entire ambient temperature operating range (10°C to 35°C).

The M910 thermal solution includes:

- Optimized airflow impedance for individual blade and chassis level airflow balancing
- Custom air baffling directs airflow through the components to maintain proper cooling
- Custom designed heat sinks maintain the processor, IOH, and chipset temperatures within thermal design targets
- Highly optimized fan control algorithm
- Base fan speeds are a function of hardware configuration and ambient temperature to minimize airflow for a given environment.
- PID control algorithms are used for both processor and DIMMs to maintain appropriate thermal margin

## 5.3 Acoustics

Table 3 shows the acoustical performance for a typical configuration of the M1000e chassis with four PowerEdge M910 blade servers installed. Acoustical performance varies with hardware configurations.

Table 3. Acoustical Performance of M1000e Chassis with Four M910 Blades Installed

Typical Configuration (per blade) @ 23±2 °C Ambient in M1000e Chassis				Operating Mode	LwA-UL (bels)
Processors	Hard Drives	DIMMs	Mezzanine Cards		
2 x Intel E7540 (105W)	2 x 2.5" SAS (10K) 146GB	24 x 4GB DDR3	4 x dual-port Broadcom® 5709	Idle	8.1

### Definitions

**Idle:** Reference ISO7779 (2010) definition 3.1.7; system is running in its OS but has no other specific activity.

**LwA-UL:** The upper limit sound power level (LwA) calculated per section 4.4.2 of ISO 9296 (1988) and measured in accordance to ISO 7779 (2010).

## 5.4 Environmental Specifications

Table 4 lists the environmental specifications for the PowerEdge M910.

Table 4. Environmental Specifications

Temperature	
Operating	10 °C to 35 °C (50 °F to 95 °F) with a maximum temperature gradation of 10 °C per hour NOTE: For altitudes above 2950 feet, the maximum operating temperature is derated 1 °F/500ft
Storage	-40 °C to 65 °C (-40 °F to 149 °F) with a maximum temperature gradation of 20 °C per hour
Relative Humidity	
Operating	20% to 80% (noncondensing) with a maximum humidity gradation of 10% per hour
Storage	5% to 95% (noncondensing) with a maximum humidity gradation of 10% per hour
Maximum Vibration	
Operating	0.26 Grms at 5-350Hz in operational orientations
Storage	1.54 Grms at 10-250Hz in all orientations

Maximum Shock	
Operating	Half sine shock in all operational orientations of 31G +/- 5% with a pulse duration of 2.6ms +/- 10%
Storage	Half sine shock on all six sides of 71 G +/- 5% with a pulse duration of 2 ms +/- 10%
Altitude	
Operating	-15.2m to 3048m (-50 to 10,000ft) Note: For altitudes above 2950ft, the maximum temperature is derated 1 °F/550ft
Storage	-16m to 10,600m (-50ft to 35,000ft)

## 6 Processors

### 6.1 Overview

The Intel® Xeon® processor E7 family and the Intel Xeon processor 6500 and 7500 series are designed specifically for servers and workstation applications. The processors feature quad-core processing to maximize performance and performance/watt for data center infrastructures and highly dense deployments. These processors also feature Intel Core™ micro-architecture and Intel 64 architecture for flexibility in 64-bit and 32-bit applications and operating systems. The Intel Xeon E7-2800, E7-4800, and E7-8800 product family and the Intel Xeon processor 6500 and 7500 series support all Streaming SIMD Extensions (including SSE2, SSE3, and SSE4) and Intel 64 instruction.

The Intel Xeon processor 6500 and 7500 series 4S (expandable processor) uses a 1567-pins Land Grid Array (LGA1567) package that plugs into a surface-mount socket. The M910 provides support for two or four processors.

Table 5. Processor Cache Sizes (Package LGA1567)

Cache	Size
L1 cache size	32 KB instruction (32 KB data)
L2 cache size	1.5 MB or 2 MB
L3 cache size	12 MB, 18 MB or 24 MB (shared)

### 6.2 Features

Key features of the Intel Xeon processor E7-2800, E7-4800, and E7-8800 product families include:

- Up to ten cores per processor
- Four point-to-point QuickPath Interconnect links at 6.4 GT/s
- 32 nm process technology
- Intel HyperThreading (2 threads/core)
- Up to 30 MB shared L3 cache
- Intel Trusted Execution Technology (TXT) and AESNI (AES New Instructions)
- RAS DDDC (Double Device Data Correct)

Key features of the Intel Xeon processor 6500 and 7500 series include:

- Up to eight cores per socket
- Up to 24 MB shared L3 cache
- 45nm process technology
- Four full-width, bidirectional point-to-point Intel QuickPath Interconnect (Intel QPI) links at 6.4 GT/s
- Support for 95 W, 105 W, and 130 W processors
- Four Intel Scalable Memory Interconnects (Intel SMI) at 6.4 GT/s
- Socket: LS, LGA 1567 package
- No termination required for non-populated processors (must populate processor socket 1 first)
- Integrated Intel QuickPath DDR3 memory controller
- 64-byte cache line size
- RISC/CISC hybrid architecture
- Compatible with existing x86 code base

## Dell

- Optimized for 32-bit code
- Intel MMX™ support
- Execute Disable Bit
- Intel Wide Dynamic Execution
- Executes up to four instructions per clock cycle
- Simultaneous Multi-Threading (SMT) capability (2 threads/core)
- Support for CPU Turbo Mode (on certain models)
- Increases processor frequency if operating below thermal, power, and current limits
- Streaming SIMD (Single Instruction, Multiple Data) Extension 4
- Intel 64 Technology
- Intel VT-x and VT-d Technology for virtualization support
- Enhanced Intel SpeedStep® Technology
- Demand-based switching for active processor power management as well as support for ACPI P-States, C-States, and T-States

### 6.3 Supported Processors

Table 6. Supported Intel Xeon Processor E7-8800 Product Family

Model	Speed	TDP Power	Cache	Cores	QPI Speed
E7-8867L	2.13GHz	105W	30M	10	6.4GT/s
E7-8837	2.66GHz	130W	24M	8	6.4GT/s

Table 7. Supported Intel Xeon Processor E7-4800 Product Family

Model	Speed	TDP Power	Cache	Cores	QPI Speed
E7-4830	2.13GHz	105W	24M	8	6.4GT/s
E7-4820	2.00GHz	105W	18M	8	5.86GT/s
E7-4807	1.86GHz	95W	18M	8	4.80GT/s

Table 8. Supported Intel Xeon Processor E7-2800 Product Family

Model	Speed	TDP Power	Cache	Cores	QPI Speed
E7-2870	2.40GHz	130W	30M	10	6.4GT/s
E7-2860	2.26GHz	130W	24M	10	6.4GT/s
E7-2850	2.00GHz	130W	24M	10	6.4GT/s
E7-2830	2.13GHz	105W	24M	8	6.4GT/s
E7-2820	2.00GHz	105W	18M	8	5.86GT/s
E7-2803	1.73GHz	105W	18M	6	4.80GT/s

Table 9. Supported Intel Xeon Processor 6500 and 7500 Series

Model	Speed	TDP Power	Cache	Cores	QPI Speed
X7560	2.26GHz	130W	24M	8	6.4GT/s
X7542	2.66GHz	130W	18M	6	5.86GT/s
X6550	2.00GHz	130W	18M	8	6.4GT/s

Model	Speed	TDP Power	Cache	Cores	QPI Speed
E7540	2.00GHz	105W	18M	6	6.4GT/s
E6540	2.00GHz	105W	18M	6	6.4GT/s
E7530	1.86GHz	105W	12M	6	5.86GT/s
E6510	1.73GHz	105W	12M	4	4.8GT/s
L7555	1.86GHz	95W	24M	8	5.86GT/s
L7545	1.86GHz	95W	18M	6	5.86GT/s
E7520	1.86GHz	95W	18M	4	4.8GT/s

## 6.4 Processor Configurations

The Dell™ PowerEdge™ M910 is designed to support either a dual processor configuration with FlexMem Bridge or a four-processor configuration. In either configuration, all I/O and memory is available in the system. While not formally supported, single processor configurations with a processor installed in CPU1 will allow the system to boot for diagnostic purposes.

The Intel Xeon E7-2800 product family and Intel Xeon processor 6500 series are for two-socket configurations only and **cannot** be upgraded to four-socket configurations.

## 6.5 FlexMem Bridge

In a four-processor configuration, the PowerEdge M910 uses only one memory controller per processor. This single controller connects to two memory buffers via Intel SMI links. Each memory buffer in turn connects to four DDR3 DIMMs. In a typical Intel Xeon processor 6500 or 7500 series configuration, only the memory buffers associated with the two populated sockets would be connected, and therefore only 16 DIMMs would be accessible.

To overcome this limitation with two processors, the M910 uses the FlexMem Bridge which allows CPU1 and CPU2 to connect to the memory of their respective adjacent sockets (CPU3 and CPU4). The FlexMem Bridge provides the following:

- Two pass-through links for SMI
- One pass-through link for QPI

The pass-through SMI links connect the two installed processors to additional SMIs, therefore the processors will have the following memory attached:

- CPU1 has access to DIMMs [A1:A8] and DIMMs [C1:C8] (those normally associated with CPU3)
- CPU2 has access to DIMMs [B1:B8] and DIMMs [D1:D8] (those normally associated with CPU4)

The pass-through QPI link on the FlexMem Bridge provides increased performance for a 2P configuration because it allows 2 full-bandwidth QPI links between CPU1 and CPU2 as opposed to a single link. Figure 4 depicts the interconnection between the CPU sockets as well as connections internal to the FlexMem Bridges. The FlexMem Bridges are only supported in sockets 3 and 4.



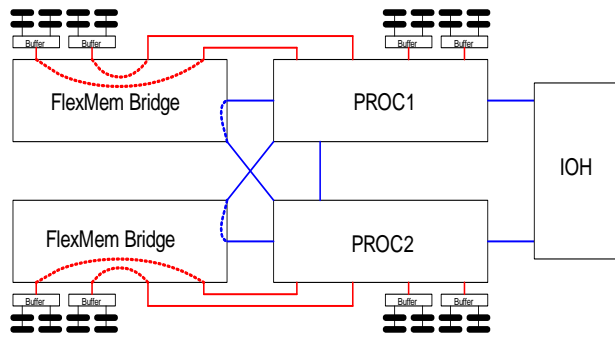

Figure 4. FlexMem Bridge Routing

Modern processors are capable of tremendous workloads, and many types of utilization patterns such as virtualization often run into memory capacity issues well before the processors reach a saturation point. FlexMem Bridge technology was designed to assist in environments that have workloads that are memory intensive.

To scale for future workloads in which additional processing power is needed, simply replace the FlexMem Bridge with additional processors to meet those needs.

Due to power limitations, the PowerEdge M910 only supports two 130W processors. In an upgrade for a server with two 130W processors, the processors and the heat sink must be changed to the 95W or 105W processors. If the server has only the 95W or 105W processors, processors can be swapped.

## 7 Memory

### 7.1 Overview

The Dell™ PowerEdge™ M910 uses DDR3 memory providing a high-performance, high-speed memory interface capable of low-latency response and high throughput. The M910 supports Registered ECC DDR3 DIMMs (RDIMM) only. Each DDR3 DIMM is driven by the Intel® 7500 Scalable Memory Buffer (SMB). A memory buffer has two DDR3 channels. Each of these channels can support up to 2 DIMMs running at 1067 MHz (or slower) speeds.

The Intel 7500 SMB supports single-, dual-, and quad-rank DIMMs. Up to four 2 GB, 4 GB, 8 GB, and 16 GB RDIMMs are supported per channel, for a total of up to 512 GB. Across processors, DIMM populations can be different on the memory for each processor as long as the population rules for each processor socket are followed. Additionally, all processor sockets operate in the same RAS mode and are set up with the same memory timing parameters.

4-socket platform capability (32 DIMMs):

- Up to 8 DDR3 DIMMs per socket through use of up to four Scalable Memory Buffers
- Support for up to 16 GB DDR3 DIMMs
- Maximum of 512 GB with 16 GB DIMMs

Memory types supported:

- 1066 MHz DDR3 (800 MHz and 1333 MHz availability depends on OEM validation)
- Registered DIMM (RDIMM)
- Single-rank (SR), dual-rank (DR), quad-rank (QR)

Actual system memory speed depends on specific processor capabilities:

- 6.4 GT/s SMI link speed capable of running memory speeds up to 1066 MHz
- 5.86 GT/s SMI link speed capable of running memory speeds up to 978 MHz
- 4.8 GT/s SMI link speed capable of running memory speeds up to 800 MHz

### 7.2 DIMMs Supported

If DIMMs of different speeds are mixed, all channels operate at the fastest common frequency. UDIMMs are not supported. The first DIMM slot in each channel is color-coded with white ejection tabs for ease of identification.

The M910's DIMM sockets are placed 0.40" apart, center-to-center, to provide enough space for sufficient airflow to cool stacked DIMMs. DIMMs must be installed in each channel starting with the DIMM farthest from the processor (DIMM 1). Population order is identified by silkscreen and a label. The order is dependent on the memory configuration used.

### 7.3 DIMM Slots

For information, see the System Memory section in the Installing Blade Components chapter of the *Dell PowerEdge Modular Systems Hardware Owner's Manual* on [Support.Dell.com/Manuals](http://Support.Dell.com/Manuals).

### 7.4 Intel 7500 Scalable Memory Buffer (SMB)

The Intel 7500 SMB supports one Intel Scalable Memory Interconnect (Intel SMI), two DDR3 channels, and one SMBus slave interface at 100 KHz. It does not support the repeater functionality. Target package size is 19.5 mm x 24.5 mm with 0.8 mm pitch. Intel SMI supports link speeds of 4.8 GT/s,

Dell

5.86 GT/s, and 6.4 GT/s with 11 Southbound lanes (9 data + 1 CRC + 1 spare) and 14 Northbound lanes (12 data + 1 CRC + 1 spare).

The DDR3 interface supports x4 and x8 single-rank, dual-rank, and quad-rank RDIMMs, and up to 2 RDIMMS per channel. Each DDR3 channel supports a maximum of 8 ranks. DDR3 speeds are 800 MHz, 978 MHz, and 1066 MHz. DRAM technology comes in 1 and 2Gb sizes. DIMM capacity is 2, 4, 8, or 16 GB (16 GB with QR DIMMS only).

## 7.5 Memory RAS Support

The Intel Xeon processor 6500 and 7500 series supports high-availability memory modes including rank and DIMM sparing as well as memory mirroring. The M910 supports rank sparing only and mirroring as shown in Table 10.

Table 10. Sparing and Mirroring Support

Sparing		Mirroring			
Type	Rules enforced	1P	2P	4P	Rules Enforced
Rank	The capacity of the spare rank must be greater than that of any other rank on the channel	No support	Inter-socket (hemisphere mode enabled)	Inter-socket	32 DIMM only, Mirrored must match

### 7.5.1 Sparing

For information, see the System Memory section in the Installing Blade Components chapter of the *Dell PowerEdge Modular Systems Hardware Owner's Manual* on [Support.Dell.com/Manuals](http://Support.Dell.com/Manuals).

### 7.5.2 Mirroring

For mirroring, the M910 will support two-processor/four-processor configurations with 32 DIMMs only. When mirroring is enabled, only half of the physical memory will be visible to the system software. A full copy of the memory is maintained, and in the event of an uncorrectable error, the system will switch over to the mirrored copy. In two-processor (2P) mode, the mirroring will be inter-node with hemisphere mode enabled. In this case, the memory controller (MBox) of CPU1 is mapped to the corresponding MBox of CPU2.

For 4-processor (4P) configurations, the PowerEdge M910 also supports mirroring in the inter-socket mode (intra-socket is not possible in 4P because each processor has only one MBox connected to memory buffers). In this 4P case, the memory on CPU1 is mirrored with memory on CPU3, while memory on CPU2 is mirrored with memory on CPU4.

## 7.6 Supported Memory Configurations

See the System Memory section in the Installing System Components chapter in the *Dell PowerEdge M910 Systems Hardware Owner's Manual* on [Support.Dell.com/Manuals](http://Support.Dell.com/Manuals).

## 8 Chipset

The Dell™ PowerEdge™ M910 system board incorporates the Intel® 7510 chipset for I/O and processor interfacing. The 7510 chipset is designed to support the Intel Xeon® E7-8800, E7-4800, and E7-2800 product family, Intel Xeon processor 6500 and 7500 series, Intel QPI Interconnect, DDR3 memory technology, and PCI Express Generation 2 (PCIe Gen2). The 7510 chipset consists of the IOH QuickPath Interconnect (QPI), Intel 7500 Scalable Memory Buffer, and the ICH10 South Bridge.

### 8.1 Intel 7500 I/O Hub (IOH)

The PowerEdge M910 system board incorporates an Intel 7500 series IOH to provide a link between the 4S processors and the I/O components. The main components of the IOH consist of two full-width QPI links (one to each processor), 36 lanes of PCIe Gen2, and a x4 DMI link to connect directly to the ICH10 (Intel I/O Controller Hub 10) South Bridge.

### 8.2 IOH QuickPath Interconnect (QPI)

The QPI architecture consists of serial point-to-point interconnects for the processors and the IOH. The PowerEdge M910 has a total of four QPI links including one link connecting the processors and links connecting both processors with the IOH. Each link consists of 20 lanes (full-width) in each direction with a link speed of 6.4 GT/s. An additional lane is reserved for a forwarded clock. Data is sent over the QPI links as packets.

The QPI architecture features the following four layers:

- The **Physical** layer consists of the actual connection between components. It supports Polarity Inversion and Lane Reversal for optimizing component placement and routing.
- The **Link** layer is responsible for flow control and the reliable transmission of data.
- The **Routing** layer is responsible for the routing of QPI data packets.
- Finally, the **Protocol** layer is responsible for high-level protocol communications, including the implementation of a MESIF (Modify, Exclusive, Shared, Invalid, Forward) cache coherence protocol.

### 8.3 PCI Express Generation 2

PCI Express (PCIe) is a serial point-to-point interconnect for I/O devices. PCIe Generation 2 (Gen2) doubles the signaling bit rate of each lane from 2.5 Gb/s to 5 Gb/s. Each of the PCIe Gen2 ports is backward-compatible with Gen1 transfer rates.

### 8.4 Direct Media Interface (DMI)

The DMI (previously called the Enterprise Southbridge Interface) connects the Intel 7500 Legacy IOH with the Intel I/O Controller Hub (ICH). The DMI is equivalent to an x4 PCIe Gen1 link with a transfer rate of 1 GB/s in each direction.

### 8.5 Intel I/O Controller Hub 10 (ICH10)

ICH10 is a highly integrated I/O controller, supporting the following functions:

- Six x1 PCIe Gen1 ports, with the capability of combining ports 1-4 as a x4 link
- PCI Bus 32-bit Interface Rev 2.3 running at 33 MHz
- Six UHCI and two EHCI (High-Speed 2.0) USB host controllers, with up to twelve USB ports
- M910 has three external USB ports and one internal ports dedicated for UIPS/RIPS and embedded storage

## Dell

- Power management interface (ACPI 3.0b compliant)
- Platform Environmental Control Interface (PECI)
- Intel Dynamic Power Mode Manager
- I/O interrupt controller
- SMBus 2.0 controller
- Low Pin Count (LPC) interface to Super I/O, Trusted Platform Module (TPM), and SuperVU
- Serial Peripheral Interface (SPI) support for up to two devices (M910 BIOS flash device is connected to the ICH10 using SPI)

## 8.6 PCI Express Mezzanine Connectors

The M910 supports four PCI Express Gen2 x8 mezzanine connectors. There are no restrictions on mezzanine cards in the M910 such as size or location.

## 9 BIOS

### 9.1 Overview

The Dell™ PowerEdge™ M910 BIOS is based on the Dell BIOS core, and supports the following features:

- IA-32 Intel Xeon 7510 chipset 4S
- Simultaneous Multi-Threading (SMT)
- CPU Turbo Mode
- PCI 2.3
- Plug-and-play 1.0a
- MP (Multiprocessor) 1.4
- Boot from hard drive, optical drive, iSCSI drive, USB key, and SD card
- ACPI
- Direct Media Interface (DMI)
- PXE and WOL support for on-board NICs
- Memory mirroring and sparing
- SETUP access through <F2> key at end of POST
- USB 2.0 (USB boot code is 1.1 compliant)
- F1/F2 error logging in CMOS
- Virtual KVM, CD
- UEFI (Unified Extensible Firmware Interface) 2.1 support

The PowerEdge M910 BIOS does not support the following:

- Embedded Diagnostics
- BIOS language localization
- BIOS recovery after bad flash (but can be recovered from iDRAC6 Enterprise)

### 9.2 Supported ACPI States

The PowerEdge M910 supports the standard ACPI states. See [www.acpi.info](http://www.acpi.info) for more information.

## 10 Embedded Gigabit Ethernet Controllers on Motherboard (LOM)

Two embedded Broadcom® 5709S dual-port LAN controllers are on the Dell™ PowerEdge™ M910 system board as independent Gigabit Ethernet interface devices. The following information details the features of the LAN devices:

- X2 PCI Express Gen2 capable interface
- M910 operates this controller at Gen2 speed
- Integrated MAC and PHY
- 3072x18 Byte context memory
- 64 KB receive buffer
- TOE (TCP Offload Engine)
- iSCSI controller
- NC-SI (Network Controller-Sideband Interface) connection for Flex Addressing
- Wake-On-LAN (WOL)
- PXE 2.0 remote boot
- iSCSI boot
- IPv4 and IPv6 support
- Bare metal deployment support

## 11 I/O Mezzanine Card Options

### 11.1 Overview

The Dell™ PowerEdge™ M910 contains four PCIe Gen2 mezzanine slots. Installation of mezzanine cards requires an M1000e I/O Module (IOM) of the same fabric technology to be installed in the corresponding fabric slot of the mezzanine to support data flow through that fabric/slot.

For more information, refer to the [PowerEdge M1000e Technical Guide](#).

### 11.2 Options

Available options for all four slots include:

- Mellanox® QDR ConnectX™ Dual-Port Quad Data Rate (QDR) InfiniBand™
- Broadcom® BCM57711 Dual Port KX4 MC (10G)
- Broadcom BCM5709S Dual Port SERDES
- Broadcom BCM5709S Quad Port SERDES
- Intel® Dual Port 10G KX4 MC
- Intel Quad Port 1G SERDES MC
- Dual Port FC8 QLogic® QME2572
- Dual Port FC8 Emulex® LPe1205-M
- QLogic CNA QME8142 (10Gb Enhanced Ethernet + FCoE)
- Emulex CNA OCM20102FM (10Gb Enhanced Ethernet)
- Intel 52599 (10Gb Enhanced Ethernet)



## 12 Storage

### 12.1 Hard Drives

The Dell™ PowerEdge™ M910 supports up to two 2.5” SAS SSD, SATA SSD, or nearline SAS hard disk drives. See Table 11 for information on supported hard drives. For the most up-to-date information on supported hard drives, visit [Dell.com](http://Dell.com).

Table 11. Supported Hard Drives

Form Factor	Capacity	Speed	Type
2.5”	50GB, 100GB	N/A	SATA SSD
2.5”	73GB, 146GB	15K	SAS
2.5”	146GB, 300GB, 600GB, 900GB	10K	SAS
2.5”	500GB, 1TB	7.2K	nearline SAS

### 12.2 Hard Disk Drive Carriers

The PowerEdge M910 supports the 11G 2.5” hard drive carrier. Legacy carriers are not supported on M910.



Figure 5. 2.5” HDD Carrier

### 12.3 Empty Drive Bays

For the slots that are not occupied by drives, a carrier blank is provided to maintain proper cooling, maintain a uniform appearance to the unit, and provide EMI shielding.

### 12.4 Diskless Configuration Support

The system supports diskless configuration with no storage controller (H200/PERC 7i) installed in the system. A 2.5” HDD backplane is installed in this configuration.

### 12.5 RAID Configurations

Table 12 lists the factory-installed RAID configurations for the PowerEdge M910.

Table 12. Factory RAID Configurations

#	Hot-Plug	Min. Hard Drives	Max. Hard Drives	Configuration	Description
0	No	0	0	ZERO	Diskless Configuration, No daughtercard
1	No	1	2	ASSN	SAS drives using SAS6/IR or H200 daughtercard with no RAID
2	No	2	2	ASSR0	SAS drives using the SAS6/IR or H200 daughtercard with drives in a RAID 0 mirror
3	Yes	2	2	ASSR1	SAS drives using the SAS6/IR or H200 daughtercard with drives in a RAID 1 Stripe
4	No	2	2	ASSCBR0	SAS or Solid State drives using the PERC6 or H700 daughtercard (with battery) with drives in a RAID 0 Stripe
5	Yes	2	2	ASSCBR1	SAS or Solid State drives using the PERC6 or H700 daughtercard (with battery) with drives in a RAID 1 mirror

## 12.6 Storage Controllers

Table 13. Supported Storage Controllers

	Product	Usage	M910	Slot	PCIe Con	PCI Bracket	I/O Con	RAID	Battery Backup
SAS HBA SAS/SATA	PERC H200 Integrated	Internal Backplane Storage	Yes, Max 1	Storage slot	X4	No	x4 integrated mini SAS wide	0, 1, 10	No

### 12.6.1 SATA Repeater

The M910 does not support the SATA repeater. The only SATA drives supported by M910 are the SSD drives which are only supported off the PERC solution.

### 12.6.2 PERC 6/i

For customers who want a hardware RAID solution, the PERC 6/i is available as an optional customer kit. The PERC 6/i uses the LSI 1078 ROC (RAID on Chip) processor with a PCI Express host interface and DDR2 memory. A battery is available with this card.

Dell

### 12.6.3 PERC H200

The M910 supports the PERC H200, which offers a battery-backed cache. Details of the PERC H200 can be found on [Support.Dell.com](http://Support.Dell.com).

### 12.6.4 PERC H700

The M910 also supports the PERC H700. Details of the PERC H700 can be found on [Support.Dell.com](http://Support.Dell.com). It offers a battery-backed cache.

## 12.7 LED Indicators

Each disk drive carrier has two LED indicators visible from the front of the system. One is a green LED for disk activity and the other is a bicolor (green/amber) LED for status. Both LEDs are used to indicate certain conditions under direction of a storage controller.

## 12.8 Optical Drives

Optical drives are optional in all M910 systems and connect to the blade via the front USB interface. The following internal slim-line drives are available on the M910:

- DVD-ROM
- DVD+RW

PATA (IDE) optical drives are not supported.

## 13 Video

The Dell™ PowerEdge™ M910 Integrated Dell Remote Access Controller 6 (iDRAC6) incorporates an integrated video subsystem connected to the 32-bit PCI interface of the ICH10. This logic is based on the Matrox® G200. The device only supports 2D graphics.

The integrated video core shares its video memory with the iDRAC6's 128 MB DDR2 application space memory. This memory is also used for the KVM buffer.

The M910 system supports the following 2D graphics video modes:

Table 14. Supported Video Modes

Resolution	Refresh Rate (Hz)	Color Depth (bit)
640 x 480	60, 72, 75, 85	8, 16, 32
800 x 600	56, 60, 72, 75, 85	8, 16, 32
1024 x 768	60, 72, 75, 85	8, 16, 32
1152 x 864	75	8, 16, 32
1280 x 1024	60, 75, 85	8, 16
1280 x 1024	60	32

## 14 Rack Information

For information on rack and cable accessories for the Dell™ PowerEdge™ M910, see the [PowerEdge M1000e Technical Guide](#) and the [M1000e Rack and Cable Advisor Tool](#).

## 15 Operating Systems

The Dell™ PowerEdge™ M910 is designed to meet the MSFT WinLogo 3.0 design specifications. For the most up-to-date information, see the [Operating System Support Matrix for Dell PowerEdge Systems](#) on Dell.com.

## 16 Virtualization

### 16.1 Overview

Table 15 lists the virtualization software supported by the M910. For the most current information, see [Support.Dell.com](http://Support.Dell.com), which also has extensive information designed to help configure virtualization software with Dell™ PowerEdge™ servers.

Table 15. Virtualization Software

Hypervisor	Factory Install	Certification
VMware® ESX/ESXi™ 3.5U5	DIB/FI/NFI	Yes
VMware® ESX/ESXi™ 4.0U1	DIB/FI/NFI	Yes
Microsoft® Windows Server® 2008 R2 with Hyper-V™	FI	Yes, included in Windows Server 2008 R2 WHQL process
Citrix® XenServer™ 5.6	FI	Yes

To configure a complete virtualization solution, another resource is the [Dell Virtualization Solution Advisor on Dell.com](http://Support.Dell.com). [Support.Dell.com](http://Support.Dell.com) also has many blade-related virtualization documents, as well as a [detailed list of the virtualization platforms that are supported by Dell OpenManage](#).

For information about what versions of VMware software have been certified on this server, see the compatibility list maintained by [VMware](http://VMware.com).

It is possible to order the server with an SD card that does not contain ESXi.

### 16.2 Advanced Infrastructure Manager by Scalent

Dell Advanced Infrastructure Manager (AIM) allows IT organizations to manage networking, storage, and servers (as well as server workloads) that can be dynamically reconfigured and deployed to meet the changing needs of today's data center environment. Specifically, AIM provides IT professionals the ability to:

- Combine new and existing networking, storage devices, and servers into a holistic computing solution that enables dynamic allocation of resources to meet application workload requirements.
- Manage physical and virtual resources with a single solution that includes the ability to move workloads seamlessly across hardware platforms for increased availability and scalability.
- Provide virtualization-like functionality to non-virtual (physical) servers, including automated failover, dynamic load balancing, and business continuity.
- Integrate existing infrastructure (networking, storage devices, and servers) into an AIM solution to provide investment protection and extend the useful life of existing data center assets.
- Significantly decrease the amount of time and people required to deploy hardware and get applications up and running by providing a repeatable, scalable framework for hardware implementation using AIM.

More information can be found at [Dell.com/AIM](http://Dell.com/AIM).

## 16.3 Vizioncore

Vizioncore's easy-to-use virtualization software products support business continuity and disaster recovery, high availability, monitoring, automation, P2V and optimization. The software is agent-less and can co-exist with other leading backup software vendors, or be used as a standalone solution.

- vRanger™ Pro is a backup and restore solution for virtualized environments.
- vFoglight™ Standard and Professional editions help organizations monitor, understand and analyze their virtual infrastructure by managing the relationships and interaction between all the components in the virtual environment.
- vConverter™ helps convert servers to the VMware®, Microsoft®, or XenServer™ or platforms.
- vReplicator is a host-level software-based replication solution for VMware infrastructure which enables companies to leverage virtualization to support High Availability (HA) and Disaster Recovery (DR) strategies.
- Vizioncore™ vOptimizer Pro helps administrators understand storage utilization so they can make real-time adjustments in allocations. It presents the financial impact of reclaimed storage per virtual machine (VM), per host, and cumulative cost savings across the enterprise through historical detailed reports.
- vControl is a VM management solution that provides self-service provisioning, multi-VM control and task-based automation. vControl lets VM consumers build and deploy VMs for themselves, while providing administrators a single interface for task-based administration of VMs.
- Vizioncore vEssentials™ is a software bundle of vFoglight Pro, vRanger Pro and vReplicator.

More information can be found at [Vizioncore.com/ASG](http://Vizioncore.com/ASG).



## 17 Systems Management

### 17.1 Overview

Dell aims on delivering open, flexible, and integrated solutions that help you reduce the complexity of managing disparate IT assets by building comprehensive IT management solutions. Combining Dell PowerEdge Servers with a wide selection of Dell-developed management solutions gives you choice and flexibility, so you can simplify and save in environments of any size. To help you meet your server performance demands, Dell offers Dell™ OpenManage™ systems management solutions for:

- Deployment of one or many servers from a single console
- Monitoring of server and storage health and maintenance
- Update of system, operating system, and application software

Dell offers IT management solutions for organizations of all sizes—priced, sized, and supported right.

### 17.2 Server Management

A Dell Systems Management and Documentation DVD and a Dell Management Console DVD are included with the product. ISO images are also available. A brief description of available content:

- **Dell Systems Build and Update Utility:** Dell Systems Build and Update Utility assists in OS install and pre-OS hardware configuration and updates.
- **OpenManage Server Administrator:** The OpenManage Server Administrator (OMSA) tool provides a comprehensive, one-to-one systems management solution, designed for system administrators to manage systems locally and remotely on a network. OMSA allows system administrators to focus on managing their entire network by providing comprehensive one-to-one systems management.
- **Management Console:** Our legacy IT Assistant console is also included, as well as tools to allow access to our remote management products. These tools are Remote Access Service, for iDRAC, and the BMC Management Utility.
- **Active Directory Snap-in Utility:** The Active Directory Snap-in Utility provides an extension snap-in to the Microsoft Active Directory. This allows you to manage Dell specific Active Directory objects. The Dell-specific schema class definitions and their installation are also included on the DVD.
- **Dell Systems Service Diagnostics Tools:** Dell Systems Service and Diagnostics tools deliver the latest Dell optimized drivers, utilities, and operating system-based diagnostics that you can use to update your system.
- **eDocs:** The section includes files for PowerEdge systems, storage peripheral, and OpenManage software.
- **Dell Management Console DVD:** The Dell Management Console is a Web-based systems management software that enables you to discover and inventory devices on your network. It also provides advanced functions, such as health and performance monitoring of networked devices and patch management capabilities for Dell systems.
- **Server Update Utility:** In addition to the Systems Management Tools and Documentation and Dell Management Console DVDs, customers have the option to obtain Server Update Utility DVD. This DVD has an inventory tool for managing updates to firmware, BIOS and drivers for either Linux® or Microsoft Windows® varieties.

## 17.3 Embedded Server Management

The Dell™ PowerEdge™ M910 implements circuitry for the next generation of Embedded Server Management. It is Intelligent Platform Management Interface (IPMI) v2.0 compliant. The optional iDRAC (Integrated Dell Remote Access Controller) is responsible for acting as an interface between the host system and its management software and the periphery devices.

The optional upgrade to iDRAC6 provides features for managing the server remotely or in data center lights-out environments.

Advanced iDRAC features require the installation of the optional iDRAC6 Enterprise card.

## 17.4 Lifecycle Controller and Unified Server Configurator

Embedded management is comprised of several interdependent pieces:

- Lifecycle Controller
- Unified Server Configurator
- iDRAC6
- vFlash media

Lifecycle controller powers the embedded management features. It is integrated and tamperproof storage for system-management tools and enablement utilities (firmware, drivers, etc.). It is flash partitioned to support multiple, future-use cases.

Dell Unified Server Configurator (USC) is a local 1:1 graphical user interface embedded on Lifecycle Controller that aids in local server provisioning in a pre-OS environment. For servers with iDRAC Express, the Lifecycle Controller offers OS install, platform updates, platform configuration, and diagnostics capabilities. For servers without iDRAC Express, this utility has limited functionality and offers OS install and diagnostics capabilities only.

To access the Unified Server Configurator, press the <F10> key within 10 seconds of the Dell logo's appearance during the system boot process. Current functionality enabled by the Unified Server Configurator includes:

Table 16. Unified Server Configurator Features and Description

Feature	Description
Faster O/S Installation	Drivers and the installation utility are embedded on system, so no need to scour DELL.COM.
Faster System Updates	Integration with Dell support automatically directed to latest versions of the Unified Server Configurator, iDRAC, RAID, BIOS, NIC, and Power Supply.
Update Rollback	Ability to recover to previous "known good state" for all updatable components.
More Comprehensive Diagnostics	Diagnostic utilities are embedded on system.
Simplified Hardware Configuration	Detects RAID controller and allows user to configure virtual disk and choose virtual disk as boot device, eliminating the need to launch a separate utility. Also provides configuration for iDRAC, BIOS, and NIC/LOM.

## 17.5 iDRAC6 Enterprise

In addition to upgrading the system with a Lifecycle Controller, iDRAC6 Enterprise offers the following key features:

- Graphical web interface
- Standard-based interfaces
- Server Sensor monitoring and fault alerting
- Secure operation of remote access functions including authentication, authorization, and encryption
- Power control and management with the ability to limit server power consumption and remotely control server power states
- Advanced troubleshooting capabilities
- Scripting capability with Dell's Racadm command-line
- Remote video, keyboard, and mouse (KVM) control with Virtual Console
- Remote media access with Virtual Media
- Dedicated network interface

Additionally, iDRAC6 can be upgraded by adding the vFlash media card. This is a 1 GB Dell branded SD card that enables a persistent 256 MB virtual flash partition.

A more detailed feature list for iDRAC6 and vFlash media is included in the table below.

Table 17. Features List for Base Management Functionality, iDRAC, and vFlash Media

Feature	Base Management Functionality	iDRAC6 Enterprise	vFlash Media
IPMI 2.0	✓	✓	✓
Web-based GUI		✓	✓
SNMP		✓	✓
WSMAN		✓	✓
SMASH-CLP		✓	✓
Racadm command-line		✓	✓
Shared/Failover Network Modes	✓	✓	✓
IPv4	✓	✓	✓
VLAN Tagging	✓	✓	✓
IPv6		✓	✓
Dynamic DNS		✓	✓
Dedicated NIC		✓	✓
Role-based Authority	✓	✓	✓
Local Users	✓	✓	✓
Active Directory		✓	✓
SSL Encryption		✓	✓

Feature	Base Management Functionality	iDRAC6 Enterprise	vFlash Media
Remote Firmware Update	✓	✓	✓
Server power control	✓	✓	✓
Serial-over-LAN (with proxy)	✓	✓	✓
Serial-over-LAN (no proxy)		✓	✓
Power capping		✓	✓
Last crash screen capture		✓	✓
Boot capture		✓	✓
Serial-over-LAN		✓	✓
Virtual media		✓	✓
Virtual console		✓	✓
Virtual console sharing		✓	✓
Virtual flash			✓
Sensor Monitoring and Alerting	✓	✓	✓
Real-time Power Monitoring		✓	✓
Real-time Power Graphing		✓	✓
Historical Power Counters		✓	✓
System Event Log	✓	✓	✓
RAC Log		✓	✓
Trace Log		✓	✓

## 17.6 Chassis Management Controller (CMC)

See the [PowerEdge M1000e Technical Guide](#).

## 18 Peripherals

### 18.1 USB peripherals

The Dell™ PowerEdge™ M910 provides an internal USB connector for a USB flash memory key. The USB memory key can be used as a boot device, security key, or mass storage device.

### 18.2 External Storage

By use of the appropriate IOMs in the M1000e chassis and mezzanine card(s) in the M910 blade, the following external storage options are available:

#### Disk Storage Options:

- Dell/EqualLogic™ PSSeries
- Dell PowerVault™ NX Series
- PowerVault MD3000i

#### Dell/EMC products:

- Dell/EMC fibre channel and/or iSCSI external storage, including Dell/EMC CX Series, AX Series, and NS Series

## Appendix A. Certifications

### A 1. Regulatory Certifications

Regulatory compliance certificates can be located at the following sites:

- <http://ausreactorprd01/reactor/xCertSearch.asp>
- [http://www.dell.com/content/topics/global.aspx/about\\_dell/values/regulatory\\_compliance/dec\\_conform?c=us&l=en&s=corp](http://www.dell.com/content/topics/global.aspx/about_dell/values/regulatory_compliance/dec_conform?c=us&l=en&s=corp)

### A 2. Product Safety Certifications

The product has been certified and bears the Mark, as applicable, of the Product Safety authorities as indicated in Table 18.

Table 18. Product Safety Certifications

Country/Region	Authority or Mark
Argentina	IRAM
Belarus	BELLIS
Canada	SCC
China	CNCA or CCC
Croatia	KONCAR
European Union	CE
Germany	TUV
IECEE	IECEE CB
Israel	SII
Kazakhstan	OTAN - CKT
Kenya	KEBS
Kuwait	KUCAS
Mexico	NYCE or NOM
Moldova	INSM
Nigeria	SONCAP
Norway	NEMKO
Russia	GOST
Saudi Arabia	KSA ICCP
South Africa	NRCS
Taiwan	BSMI
Ukraine	UKRTEST or UKRSERTCOMPUTER
United States	NRTL
Uzbekistan	STZ

### A 3. Electromagnetic Compatibility

The product has been certified and bears the Mark, as applicable, of the EMC authorities as indicated in Table 19.

Table 19. Electromagnetic Compatibility Certifications

Country/Region	Authority or Mark	Class
Australia/New Zealand	ACMA or C-Tick	Class A
Belarus	BELLIS	Class A
Bosnia & Herzegovina, Montenegro, Serbia	KVALITET	Class A
Canada	ICES	Class A
China	CNCA or CCC	Class A
Croatia	KONCAR	Class A
European Union	CE	Class A
Israel	SII	Class A
Japan	VCCI	Class A
Kazakhstan	OTAN - CKT	Class A
Moldova	INSM	Class A
Norway	NEMKO	Class A
Russia	GOST	Class A
South Africa	SABS	Class A
South Korea	KCC	Class A
Taiwan	BSMI	Class A
Ukraine	UKRTEST or UKRSERTCOMPUTER	Class A
United States	FCC	Class A
Uzbekistan	STZ	Class A
Vietnam	ICT	Class A

### B 1. Ergonomics, Acoustics and Hygienics

The product has been certified and bears the Mark, as applicable, of the Ergonomics, Acoustics and Hygienics authorities as indicated in Table 20.

Table 20. Ergonomics, Acoustics and Hygienics

Country/Region	Authority or Mark
Belarus	BELLIS
Germany	GS
Russia	GOST

## Appendix B. Industry Standards

The Dell™ PowerEdge™ M910 system conforms to the industry standards detailed in Table 21.

Table 21. Industry Standards

Standard	URL for Information and Specifications
<b>ACPI</b> Advance Configuration and Power Interface Specification, v2.0c	<a href="http://www.acpi.info/">http://www.acpi.info/</a>
<b>ENERGY STAR®</b> EPA Version 1.0 of the Computer Server specification	<a href="http://www.energystar.gov/index.cfm?c=archives.enterprise_servers">http://www.energystar.gov/index.cfm?c=archives.enterprise_servers</a>
<b>Ethernet</b> IEEE 802.3-2005	<a href="http://standards.ieee.org/getieee802/802.3.html">http://standards.ieee.org/getieee802/802.3.html</a>
<b>IPMI</b> Intelligent Platform Management Interface, v2.0	<a href="http://www.intel.com/design/servers/ipmi/">http://www.intel.com/design/servers/ipmi/</a>
<b>DDR3 Memory</b> DDR3 SDRAM Specification, Rev. 3A	<a href="http://www.jedec.org/download/search/JESD79-3A.pdf">http://www.jedec.org/download/search/JESD79-3A.pdf</a>
<b>LPC</b> Low Pin Count Interface Specification, Rev. 1.1	<a href="http://developer.AMD.com/design/chipsets/industry/lpc.htm">http://developer.AMD.com/design/chipsets/industry/lpc.htm</a>
<b>PCI Express</b> PCI Express Base Specification Rev. 2.0	<a href="http://www.pcisig.com/specifications/pciexpress/">http://www.pcisig.com/specifications/pciexpress/</a>
<b>PMBus</b> Power System Management Protocol Specification, v1.1	<a href="http://pmbus.info/specs.html">http://pmbus.info/specs.html</a>
<b>SAS</b> Serial Attached SCSI, v1.1	<a href="http://www.t10.org/cgi-bin/ac.pl?t=f&amp;f=sas1r10.pdf">http://www.t10.org/cgi-bin/ac.pl?t=f&amp;f=sas1r10.pdf</a>
<b>SATA</b> Serial ATA Rev. 2.6; SATA II, Extensions to SATA 1.0a, Rev. 1.2	<a href="http://sata-io.org/">http://sata-io.org/</a>
<b>SMBIOS</b> System Management BIOS Reference Specification, v2.6	<a href="http://www.dmtf.org/standards/smbios/">http://www.dmtf.org/standards/smbios/</a>
<b>TPM</b> Trusted Platform Module Specification, v1.2	<a href="http://www.trustedcomputinggroup.org/resources/tpm_main_specification">http://www.trustedcomputinggroup.org/resources/tpm_main_specification</a>
<b>UEFI</b> Unified Extensible Firmware Interface Specification, v2.1	<a href="http://www.uefi.org/specs/">http://www.uefi.org/specs/</a>



Dell

Standard	URL for Information and Specifications
<b>USB</b> Universal Serial Bus Specification, Rev. 2.0	<a href="http://www.usb.org/developers/docs/">http://www.usb.org/developers/docs/</a>
<b>Windows Logo</b> Microsoft® Windows® Logo Program System and Device Requirements, v3.10	<a href="http://www.microsoft.com/whdc/winlogo/hwrequirements.msp">http://www.microsoft.com/whdc/winlogo/hwrequirements.msp</a>